

# 三爪夹 Three Jaws Gripper

型材 · SUS Tube  
Profile · SUS Tube

支架模组  
Stents Module

快换  
Quick Changer

夹具组件  
Grip Module

气动剪刀  
Air Nipper

真空组件  
Vacuum Module

附件  
Accessory Components



| 货号(PN)                                                          | 1.Y04529                                               | 1.Y04764  | 1.Y05750  |    |
|-----------------------------------------------------------------|--------------------------------------------------------|-----------|-----------|----|
| 型号(Model)                                                       | GMHS3-16D                                              | GMHS3-20D | GMHS3-25D |    |
| 缸径 Bore                                                         | 16                                                     | 20        | 25        |    |
| 使用流体 Fluid                                                      | 空气 Air                                                 |           |           |    |
| 使用压力范围 Operating pressure range                                 | 0.2~0.6MPa                                             |           |           |    |
| 环境及流体温度 Environment and fluid temperature                       | -10~60°C                                               |           |           |    |
| 重复精度(mm) Repeatability accuracy                                 | ±0.01                                                  |           |           |    |
| 最高使用频率(c.p.m) Maximum frequency of use                          | 120c.p.m                                               |           |           |    |
| 动作方式 action mode                                                | 双作用 Double action                                      |           |           |    |
| 注)夹持力N<br>压力0.5MPa<br>Note) gripping force N<br>Pressure 0.5MPa | 外径夹持<br>External diameter clamping                     | 14        | 25        | 42 |
|                                                                 | 内径夹持<br>Internal diameter clamping                     | 16        | 28        | 47 |
|                                                                 | 带防尘罩外径夹持<br>External diameter clamping with dust cover | 9         | 21        | 36 |
| 带罩·标准型手指行程<br>Standard finger stroke with hood                  | 4                                                      | 4         | 6         |    |
| 长行程手指行程<br>Long stroke finger stroke                            | 10                                                     | 10        | 12        |    |
| 接管口径Rc Pipe Size                                                | M3×0.5                                                 | M5×0.8    |           |    |
| 磁性开关 Magnetic switch                                            | 内置磁环型 Built in magnetic ring type                      |           |           |    |

注)夹持外径时的夹持力, Ø16-Ø25的夹持点距离L=20mm时的数值  
Note)Clamping force when holding the outside diameter,  
The value of the holding point of Ø16-Ø25 is L=20mm

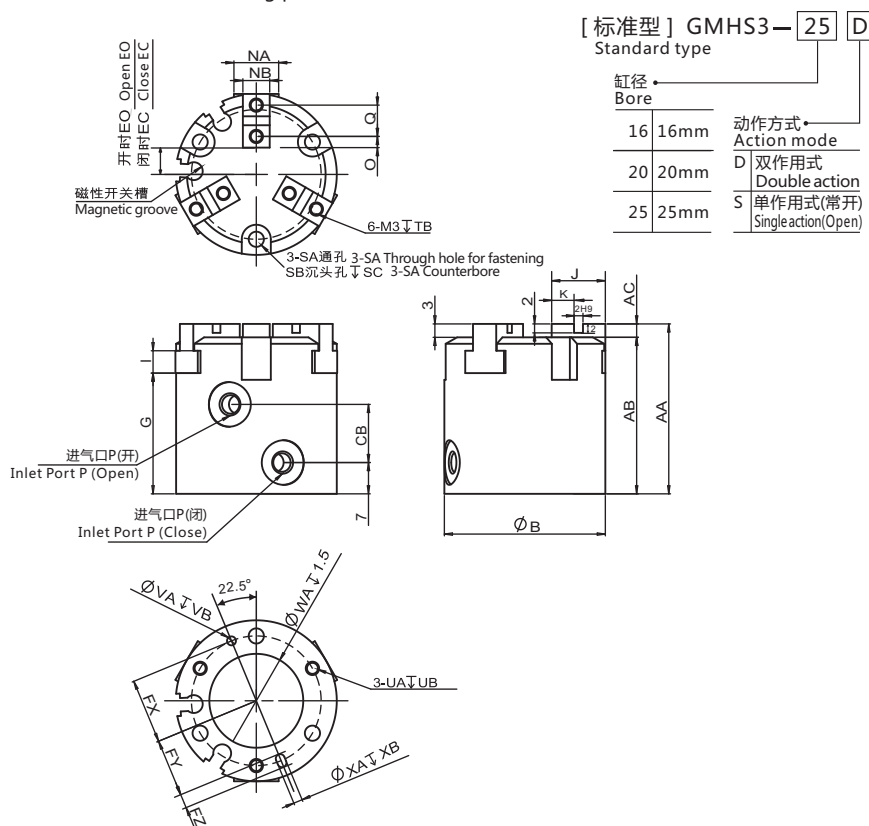

| 缸径(Bore) | AA | AB | B  | CB | EC | EO | FX   | FY   | FZ | G  | I | J  | K | NA | NB  |
|----------|----|----|----|----|----|----|------|------|----|----|---|----|---|----|-----|
| 16       | 35 | 32 | 30 | 11 | 5  | 7  | 12.5 | 11   | 3  | 25 | 4 | 10 | 4 | 8  | 5h9 |
| 20       | 38 | 35 | 36 | 13 | 6  | 8  | 14.5 | 13   | 3  | 27 | 5 | 12 | 5 | 10 | 6h9 |
| 25       | 40 | 37 | 42 | 15 | 7  | 10 | 17   | 14.5 | 5  | 28 | 5 | 14 | 6 | 12 | 6h9 |

| 缸径(Bore) | O   | P      | Q | SA  | SB  | SC  | TB | UA     | UB  | VA  | VB | WA   | XA  | XB |
|----------|-----|--------|---|-----|-----|-----|----|--------|-----|-----|----|------|-----|----|
| 16       | 2   | M3x0.5 | 6 | 3.4 | 6.5 | 8   | 5  | M3x0.5 | 4.5 | 2H9 | 2  | 17H9 | 2H9 | 2  |
| 20       | 2.5 | M5x0.8 | 7 | 3.4 | 6.5 | 9.5 | 6  | M3x0.5 | 6   | 2H9 | 2  | 21H9 | 2H9 | 2  |
| 25       | 3   | M5x0.8 | 8 | 4.5 | 8   | 10  | 6  | M4x0.7 | 6   | 3H9 | 3  | 26H9 | 3H9 | 3  |